

Action code: **WHEN CONVENIENT**

**Guidelines on Operation on Distillate Fuels**  
Low-viscosity fuels

SL09-515/CXR  
September 2009

**Concerns**

Owners and operators of MAN B&W two-stroke diesel engines.

**Summary**

Guidelines on low-viscosity fuel. MAN Diesel recommends fuels with a viscosity of 2 cSt at engine inlet.

Dear Sirs

With the introduction of new and tighter fuel sulphur content regulations by the EU and the California Air Resources Board, MAN B&W two-stroke engines will increasingly operate on distillate fuels, i.e. marine gas oil (MGO) and marine diesel oil (MDO) in such areas where required.

MAN B&W two-stroke engines are optimised to operate on heavy fuel. However, MGO/MDO fuels can be used when appropriate considerations are made to the following to ensure a safe and reliable performance, i.e.:

- the viscosity and lubricity of the fuel
- keeping a high fuel pump pressure
- the use of a cooler or chiller in an external fuel supply system
- other considerations, references for more information.

This service letter gives guidelines and recommendations on how to ensure a safe and reliable operation on low-viscosity distillate fuels.

For any questions or inquiries regarding the recommendations in this service letter, please contact our Operation Department at the e-mail address: [leo@mandiesel.com](mailto:leo@mandiesel.com)

Yours faithfully

  
**Ole Grøne**  
Senior Vice President  
Promotion and Sales

  
**Kjeld Aabo**  
Director  
Promotion and Customer Support



DIESELswitch for automatic change-over between HFO and MGO/MDO

**Head office (& postal address)**  
**MAN Diesel**  
Teglhølmegade 41  
2450 Copenhagen SV  
Denmark  
Phone: +45 33 85 11 00  
Fax: +45 33 85 10 30  
[mandiesel-cph@mandiesel.com](mailto:mandiesel-cph@mandiesel.com)  
[www.mandiesel.com](http://www.mandiesel.com)

**PrimeServ**  
Teglhølmegade 41  
2450 Copenhagen SV  
Denmark  
Phone: +45 33 85 11 00  
Fax: +45 33 85 10 49  
[PrimeServ-cph@mandiesel.com](mailto:PrimeServ-cph@mandiesel.com)

**Production**  
Teglhølmegade 35  
2450 Copenhagen SV  
Denmark  
Phone: +45 33 85 11 00  
Fax: +45 33 85 10 17  
[manufacturing-dk@mandiesel.com](mailto:manufacturing-dk@mandiesel.com)

**Forwarding & Receiving**  
Teglhølmegade 35  
2450 Copenhagen SV  
Denmark  
Phone: +45 33 85 11 00  
Fax: +45 33 85 10 16

**MAN Diesel**  
Branch of MAN Diesel SE, Germany  
CVR No.: 31611792  
Head office: Teglhølmegade 41  
2450 Copenhagen SV, Denmark  
German Reg.No.: HRB 22056  
Amtsgericht Augsburg

## Contents

Introduction	page 2
ISO 8217	page 2
Influence of lubricity and viscosity	page 2
Fuel oil pump pressure	page 3
Installation of cooler or chiller & cooler	page 4
Other considerations	page 5

## Introduction

The lowest viscosity suitable for two-stroke diesel engines is 2 cSt at engine inlet. However, this viscosity limit cannot necessarily be used as a fuel specification for purchasing the fuel, as the viscosity in a purchase specification is tied to a reference temperature. This is due to the fact that the external fuel systems have an individual effect on the heating of the fuel and, thereby, the viscosity of the fuel when it reaches the engine inlet.

The external fuel oil systems on board today have been designed to keep a high temperature for HFO operation. This can make it difficult to keep the fuel system temperature as low as possible, and thereby as high a viscosity as possible, when changing to DO and GO operation. The crew must therefore make an individual test.

Many other factors influence viscosity and its influence on the engine, such as engine condition and maintenance, fuel pump wear, engine adjustment, actual fuel temperature in the fuel system, human factors, etc. Although achievable, it is difficult to optimise all of these factors at the same time. This complicates operation on viscosities in the lowest end of the viscosity range.

To build in some margin for safe and reliable operation, MAN Diesel recommends operators to test the engine's and external systems' sensitivity to low viscosity. Furthermore, the necessity for installation of a cooler or cooler & chiller should be evaluated before purchasing fuels with the minimum level of viscosity necessary.

In principle, fuels according to the specified grades DMX/DMA can be purchased, if the engine and external system are designed to keep a minimum viscosity of 2 cSt at engine inlet. If 3 cSt can be obtained, this is preferred to ensure a higher safety margin.

## ISO 8217

According to ISO 8217, distillate grades DMX/DMA can be sold with a viscosity down to 1.4/1.5 cSt at 40°C. This will especially be the case if the DMX/DMA provided origins from automotive gas oil. The 1.4/1.5 cSt can only be applied if the distillate is cooled/chilled down correspondingly to reach the 2 cSt minimum viscosity at engine inlet.

## Influence of lubricity and viscosity

### Lubricity

The refinery processes intended to remove, e.g., sulphur from the oil result not only in low viscosity, but also impacts the lubricity enhancing components of the fuel. Too little lubricity may result in fuel pump seizures.

Although most refiners add lubricity-enhancing additives to distillates, MAN Diesel recommends testing the lubricity before using fuels with less than 0.05% sulphur. Independent fuel laboratories can test lubricity according to ISO12156-1 (High-Frequency Reciprocating Rig, HFRR). The HFRR wear scar limit is max 460  $\mu\text{m}$ .

### Viscosity

A low viscosity fuel oil challenge the function of the pump in three ways: 1. Breakdown of hydrodynamic oil film (resulting in seizures), 2. Insufficient injection pressure (resulting in difficulties during start and low-load operation), and 3. Insufficient fuel index margin resulting in limitation in acceleration.

Due to the design of conventional pumps versus the pressure booster, ME/ME-C/ME-B engines are more tolerant towards a low viscosity compared with the MC/MC-C engines. Many factors influence the viscosity tolerance during start and low-load operation:

- Engine condition and maintenance
- Fuel pump wear
- Engine adjustment
- Actual fuel temperature in the fuel system
- Human factors, etc.

Although achievable, it is difficult to optimise all of these factors at the same time. This complicates operation on viscosities in the lowest end of the viscosity range. To build in some margin for safe and reliable operation, and availability of high-viscosity distillate fuels, it is expected that installation of coolers or cooler & chiller will be necessary for many operators.

## Fuel oil pump pressure

Worn fuel pumps increase the risk of starting difficulties, as the fuel oil pump pressure needed for injection cannot be achieved. An indication of fuel pump wear can be achieved by reading the actual fuel pump index for comparison with the test bed measurements. As a rough guideline, we consider the pump worn out when the index increase is 10 or more. Such fuel pumps should be replaced for better engine performance.

It is always advisable to make start checks at regular intervals. However, as distillates of required minimum viscosity may not be available in all ports, it is an imperative necessity to perform start checks prior to entering high-risk areas (e.g. ports and other congested areas). By such action, the individual low viscosity limit can be found for each engine. It is recommended to perform such a check twice a year, in the following way:

- In an area for safe operation, change fuel to an available distillate.

- At different operating conditions, e.g. start, idle, astern and steady low rpm, gradually change the temperature of the fuel at engine inlet, corresponding to respectively 2, 2.5 and 3 cSt, see Fig. 1 for the typical viscosity and temperature relationship.
- Test start ahead/astern from the control room. If the engine does not start at the first attempt, cancel and repeat the start attempt. If the start ahead/astern functions properly with cancelled limiter, this solution can be used temporarily until either new fuel pumps are installed or a higher viscosity fuel becomes available.

An outcome of the test might be that the specific engine requires a viscosity that cannot be kept due to the influence from the many factors. If the fuel pumps are worn, they must be replaced and the start check repeated.

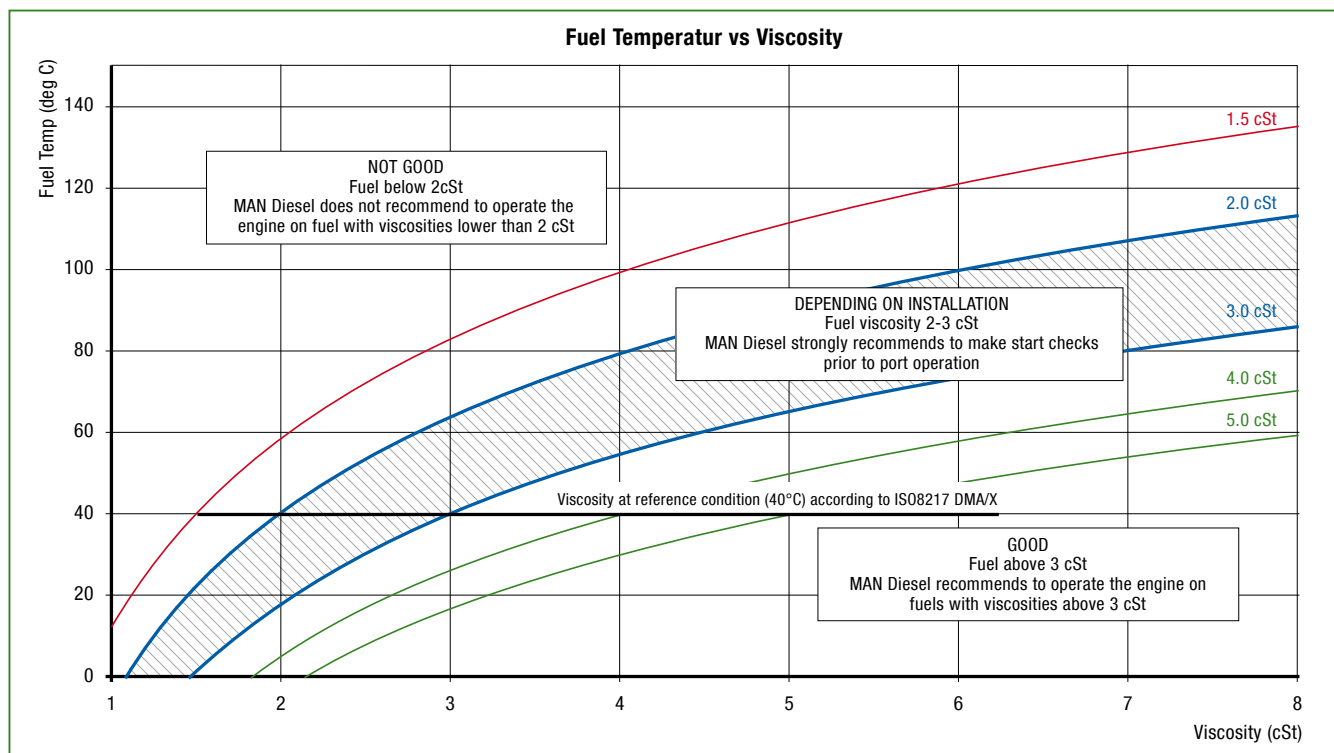

The horizontal axis shows the bunkered fuel viscosity in cSt, which should be informed in the bunker analysis report. If the temperature of the MGO is below the lower red curve at engine inlet, the viscosity is above 3 cSt.

The black thick line shows the viscosity at reference condition (40°C) according to ISO8217, marine distillates.

Example: MGO with viscosity of 4 cSt at 40°C must have a temperature below 55°C at engine inlet to ensure a viscosity above 3 cSt.

Example: MGO with a viscosity of 5 cSt at 40°C is entering the engine at 50°C. The green curves show that the fuel enters the engine at approximately 4.0 cSt.

Example: MGO with a viscosity of 2 cSt at 40°C needs cooling to 18°C to reach 3 cSt.

Fig. 1: Fuel temperature vs viscosity

### Installation of cooler or cooler & chiller

To be able to maintain the required viscosity at the engine inlet, it is necessary to install a cooler in the system. Fig. 2 shows the recommended location to install a cooler.

For the lowest viscosity distillates, a cooler may not be enough to cool the fuel sufficiently due to the cooling water available onboard. In such a case, it is recommended to install a so-called 'chiller'. The chiller principle is shown in Fig. 3.

### External pumps

Not only will the engine fuel pumps be influenced by the fuel viscosity. Also most pumps in the external system (supply pumps, circulating pumps, transfer pumps and feed pumps for the centrifuge) need viscosities above 2 cSt to function properly. We recommend contacting the actual pump maker for advice.

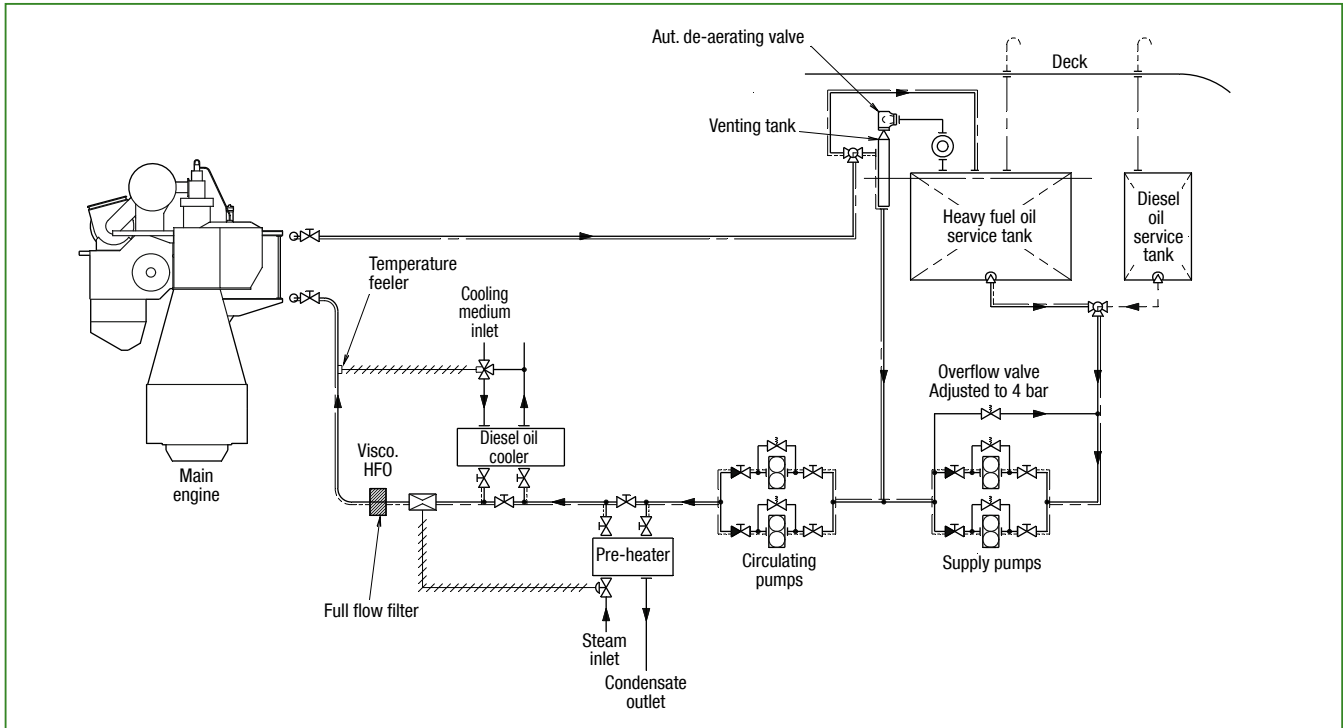

Fig. 2: Fuel system (cooler installed after the circulating pumps)

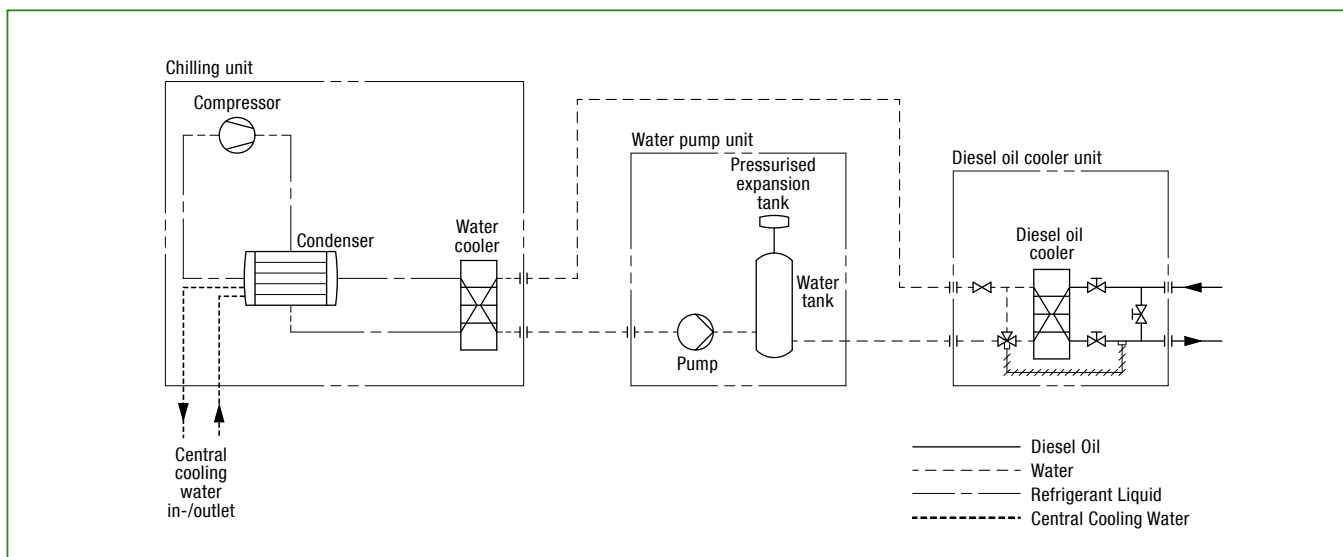

Fig. 3: Chiller principle

## Other considerations when operating on distillates

The following items are described in more detail in a separate MAN Diesel paper "Operating on distillate fuels":

- external pumps
- pour point restrictions (distillates should not be cooled below pour point)
- change-over between HFO and MGO/MDO (to ensure optimal conditions for the fuel pumps)  
*Also described in the instruction book, Operation*
- DIESELswitch for automatic change-over between HFO and MGO/MDO
- correlation between fuel sulphur level and cylinder condition (choice of cylinder lube oil).

Contact PrimeServ for more information on installation of coolers/chillers and DIESELswitch (e-mail: [Primeserv-cph@mandiesel.com](mailto:Primeserv-cph@mandiesel.com)).

For operational assistance, please contact our Operation Department at e-mail: [leo@mandiesel.com](mailto:leo@mandiesel.com).